

WPio20

Lithium-Ion Low Lift Pallet Truck
2.000 kg

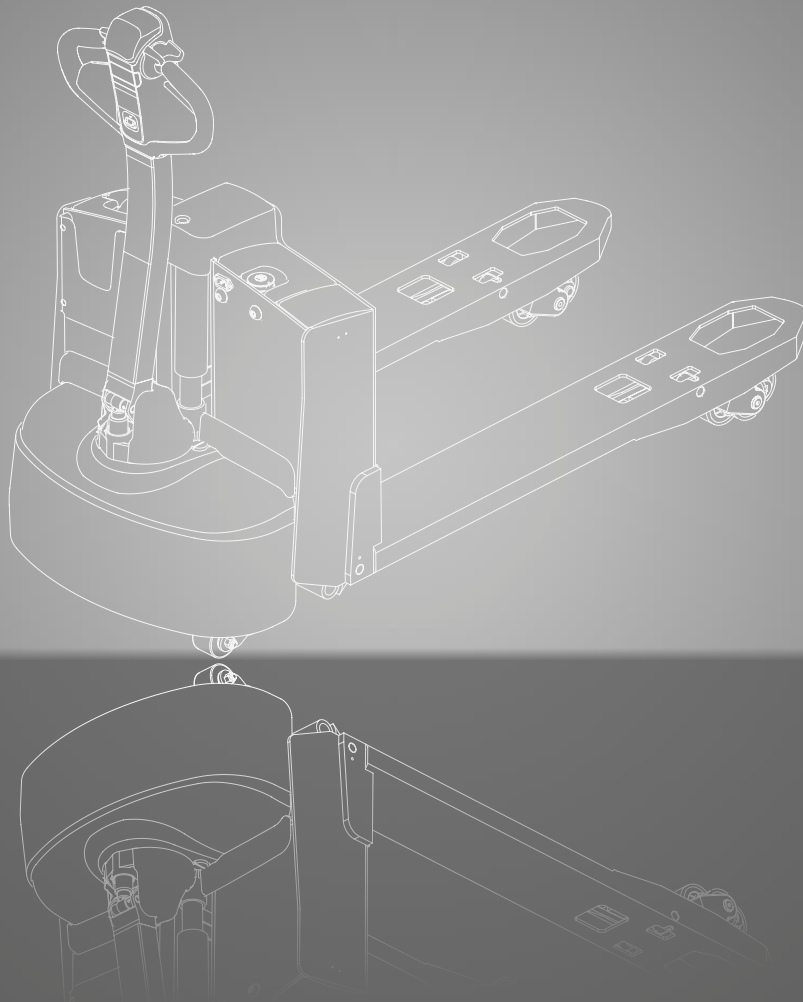

DIMENSIONS

WPio20

$$R_h = \sqrt{x^2 + \left(\frac{b_{12}}{2}\right)^2}$$

$$A_{st} = W_a + l_6 - x + a \text{ if } R_h < W_a$$

$$A_{st} = R_h + l_6 - x + a \text{ if } R_h > W_a$$

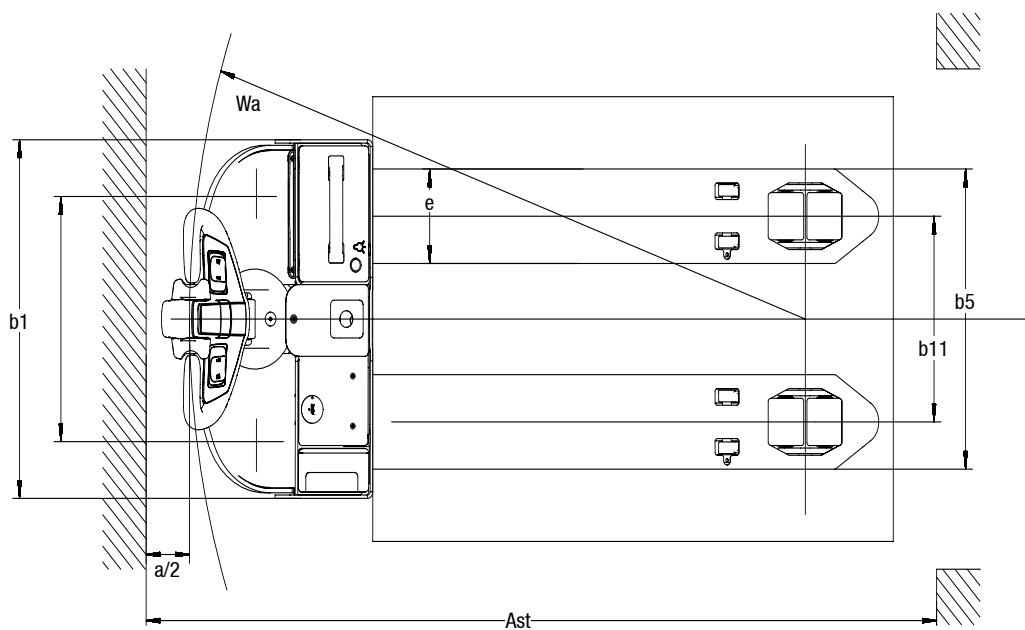
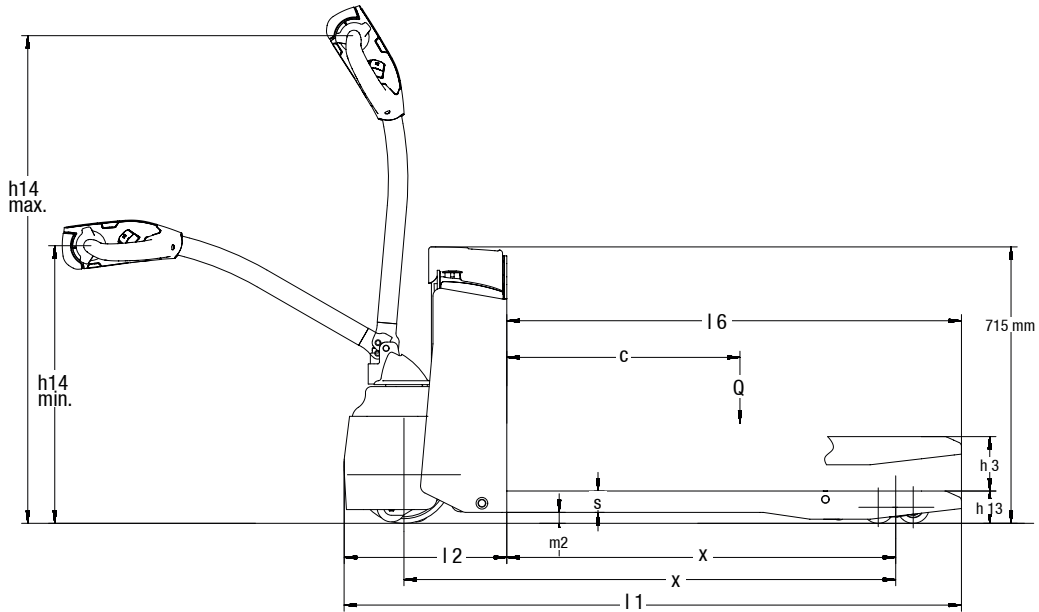

For corresponding data see specification chart.

SPECIFICATIONS

Product Specification acc. to VDI 2198

1.1 Manufacturer (Abbreviation)		CLARK
Specifications	1.2 Manufacturer's designation	WPio20
	1.3 Drive	48V Electric
	1.4 Operator type	Pedestrian
	1.5 Rated capacity/rated load	Q (kg) 2.000
	1.6 Load centre distance	c (mm) 600
	1.8 Load distance	x (mm) 1.000
	1.9 Wheelbase	y (mm) 1.268
Weight	2.1 Service weight incl. battery (see 6.5)	kg 250
	2.2 Axle loading, laden front/rear	kg 685 / 1.565
	2.3 Axle loading, unladen front/rear	kg 185 / 65
Tyres, Chassis	3.1 Tyres	Polyurethane
	3.2 Tyre size, front	Ø 245 x 94
	3.3 Tyre size, rear	2 x Ø 80 x 85 / Ø 80 x 115
	3.4 Additional wheels (dimensions)	Ø 74 x 48
	3.5 Wheels, number front/rear (x = driven wheels)	1 x + 2 / 4 / 1 x + 2 / 2
	3.6 Tread, front	b10 (mm) 441
	3.7 Tread, rear	b11 (mm) 370
Dimensions	4.4 Lift	h3 (mm) 140
	4.4 Lift height	h3 + h13 (mm) 222,5
	4.9 Height tiller in driving position min./max.	h14 (mm) 716 / 1.240
	4.15 Height, lowered	h13 (mm) 82,5
	4.19 Overall length (without platform)	l1 (mm) 1.592
	4.20 Length to face of forks (without platform)	l2 (mm) 423
	4.21 Overall width	b1 (mm) 645
	4.22 Fork dimensions	s • e • l (mm) 55 x 170 x 1.170
	4.25 Distance between fork-arms	b5 (mm) 540
	4.32 Ground clearance, centre of wheelbase	m2 (mm) 27
4.33 Aisle width for pallets 1.000 x 1.200 sideways	Ast (mm) 2.228	
4.34 Aisle width for pallets 800 x 1.200 lengthways	Ast (mm) 2.076	
4.35 Turning radius	Wa (mm) 1.428	
Performance	5.1 Travel speed, laden/unladen	km/h 5.0 / 5.5
	5.2 Lift speed, laden/unladen	m/s 0.028 / 0.04
	5.3 Lowering speed, laden/unladen	m/s 0.04 / 0.022
	5.8 Max. gradeability, laden/unladen *1	% 6 / 16
	5.10 Service brake	Electric
Electrics	6.1 Drive motor rating S2 60 min	kW 0.9
	6.2 Lift motor rating at S3 15 %	kW 0.84
	6.3 Battery acc. to DIN 43531/35/36 A, B, C, no	No
	6.4 Battery voltage/nominal capacity (5hr)	V/Ah 48 / 30
	6.5 Battery weight	kg 14
	6.6 Energy consumption acc. to VDI cycle	kWh/h -
	- Battery type	Lithium-ion
8.1 Type of drive unit	DC	
Misc.	10.5 Steering design	Mechanical
	10.7 Sound pressure level at the driver's seat acc. to EN 12053	dB(A) 74

*1) At friction coefficient $\mu=0.6$ with 1.6 km/h

All data refer to trucks in standard design.

Performance may vary + 5 % and - 10 % due to motor and system efficiency tolerance. The performance shown represents nominal values which may be obtained under typical operating conditions of a machine. CLARK products and specifications are subject to change without notice.

EQUIPMENT EXTRAS

		WPio20
General	Easy to handle lithium-ion battery (14 kg)	•
	Truck net weight, including battery 250 kg	•
	Internal charger (15 Ah)	•
	External charger (15 Ah)	X
	Electrical drive system, lift and lowering	•
Drive Options	Tandem load wheel (polyurethane)	•
	Single load wheel (polyurethane)	X
	Additional lithium-ion battery	X
	Battery discharge indicator	•
Dimensions	Distance between fork-arms: 540 mm	•
	Distance between fork-arms: 600 mm / 685 mm	X
	Fork length 1.170 mm	•
	Fork length 850 mm, 1.000 mm, 1.220 mm, 1.450 mm or 1.600 mm	X
Safety	Key switch activation via smart key	•
	Monitored by battery management system	•
	Automatic lift stop at maximum lift	•
	Gradient anti-roll-back	•
	Automatic parking brake	•
	Belly switch	•

• = Standard Equipment; x = Option

FEATURES & ADVANTAGES

WPio20

Electrical lifting and lowering

- Sensitive lifting and lowering
- Drive and operating controls in easy reach position
- Automatic braking when the tiller arm is released
- Suitable for both left- and right-handed users

Smart Key

- Smart-Key activation
- Easy to use
- Access control

Smart Display

- Battery discharge indicator
- Operating hour counter
- Battery management system
- On-board diagnostics via error codes

Application

- Powerful 48 Volt drive with Li-ion-Power
- Smooth and quiet operation
- Always usable with the lithium-ion battery from top-up charging
- Quick charging times
- Programmability for adapted driving behavior
- Maneuverability in tight corners
 - Total width (b1) only 645 mm
 - Length to fork face (l2) only 423 mm
 - Turning radius (WA) only 1.428 mm

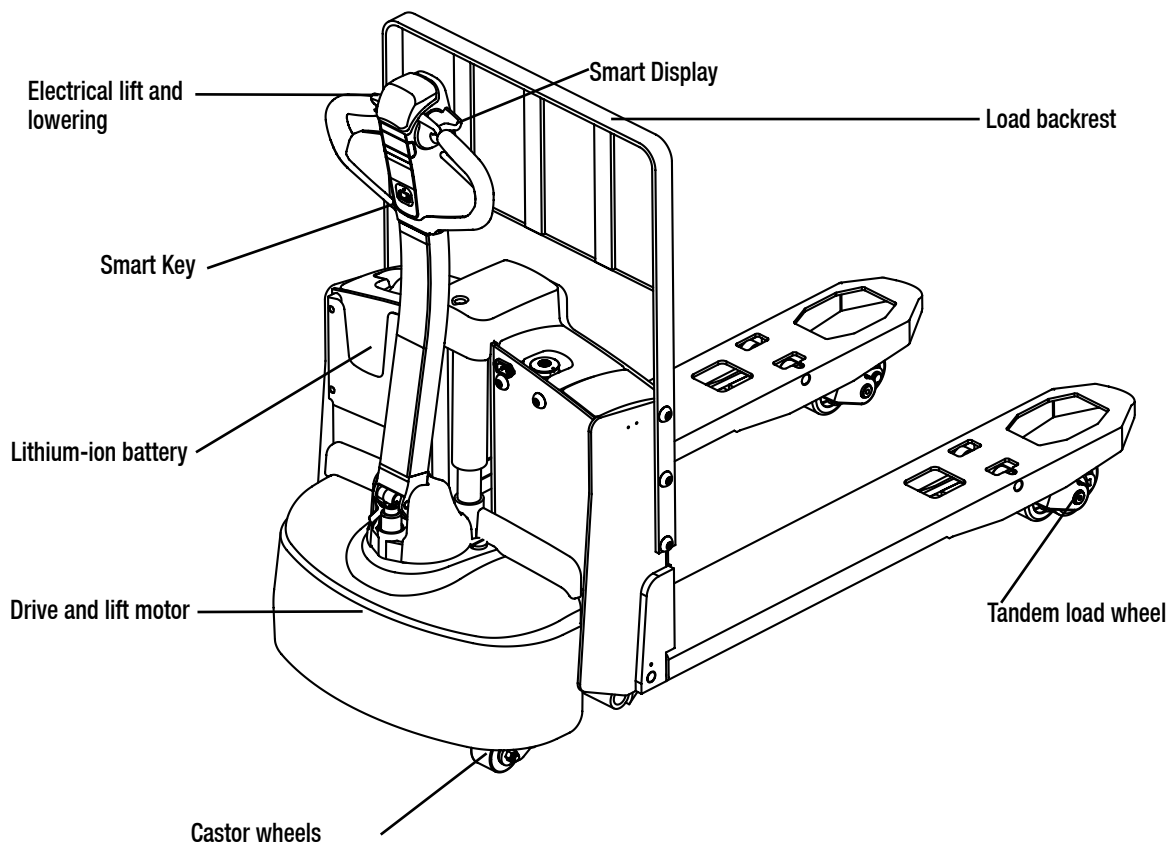

WPio20

The WPio20 – The compact power pack

The WPio20 is a lithium-ion powered low lift pallet truck with capacity up to 2.000 kg. It is ideal for transporting all kinds of goods over short distances. The minimal L2 dimension (length to face of forks) of only 423 mm, makes the WPio20 extremely compact and ideal for use in confined spaces, e.g. in stores and business centres of all types. A further advantage is the low service weight of only 250 kg.

Thanks to the maintenance-free lithium-ion battery and the included charger daily routines stay much the same when a conventional low lift pallet truck is replaced with the WPio20. The WPio20 is perfect for medium intensive application in goods distribution, production tasks or warehouse applications. In addition, a small lamp in the Lithium-ion battery allows lightened dark storage areas.

Advantages of Lithium-ion technology in the WPio20

High performance in a compact design

The high energy density of the installed lithium-ion battery provides great travel performance and long operating periods of up to 3,2 hours. At the same time, the WPio20 is very compact and has a low service weight, which means it consumes up to 30 % less energy than vehicles with lead-acid batteries.

Fast charging + top-up charging

Up to 5 % of battery capacity can be recharged in just 10 minutes. Top-up charging can be used between full charges without affecting the service life of the battery. The battery can be recharged with any 230-V socket. A completely discharged battery is fully charged in about 3,5 hours.

Double service life + maintenance-free battery

The Lithium-ion battery has approximately twice the service life of a conventional lead-acid battery. In addition, no maintenance work is required, such as checking the water level around the Lithium-ion battery. No costs are incurred for adapting the existing charging infrastructure (e.g. ventilation).

CLARK Europe GmbH
Dr.-Alfred-Herrhausen-Allee 33
47228 Duisburg / Germany
Tel.: +49 (0)2065 499 13-0
Fax: +49 (0)2065 499 13-290
E-Mail: Info-europe@clarkmheu.com
www.clarkmheu.com

Dealer: