



THE FORKLIFT

# SRX14/16

Electric Reach Truck

1.400 kg 1.600 kg

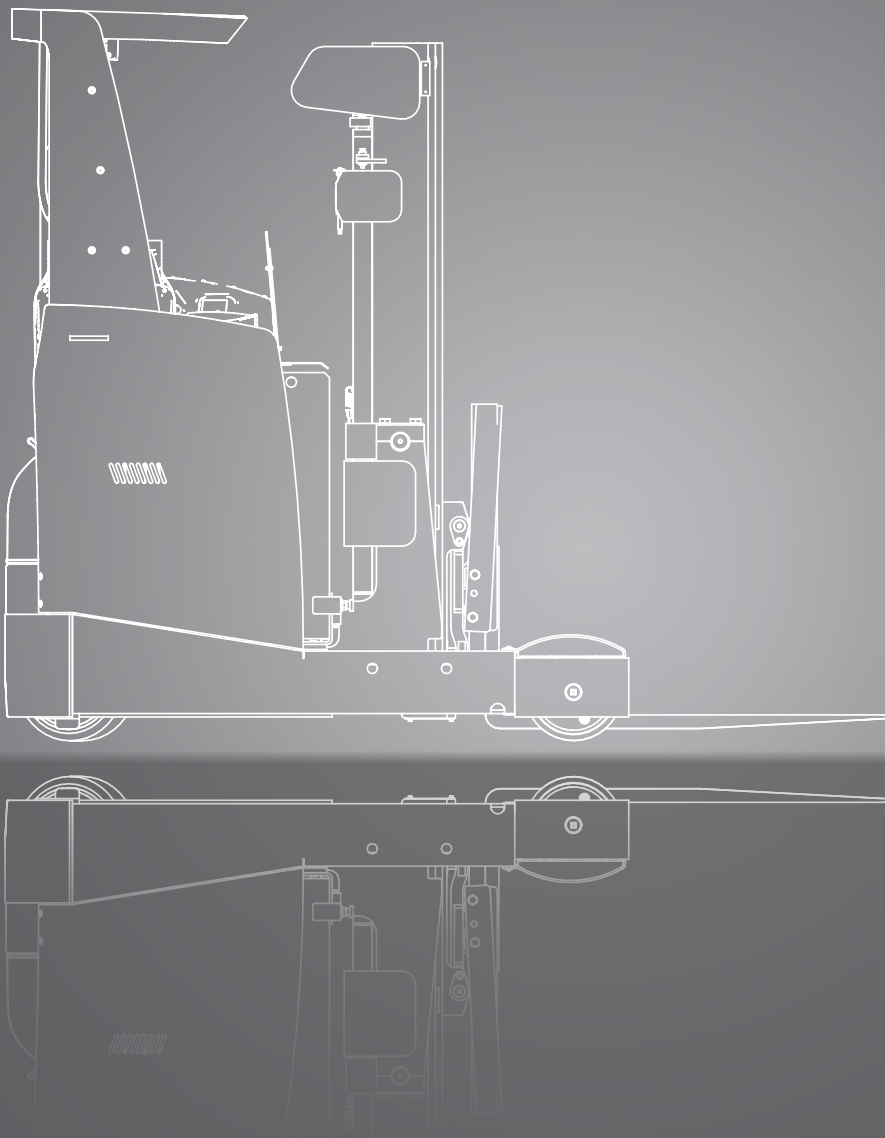

# DIMENSIONS

## SRX14/16

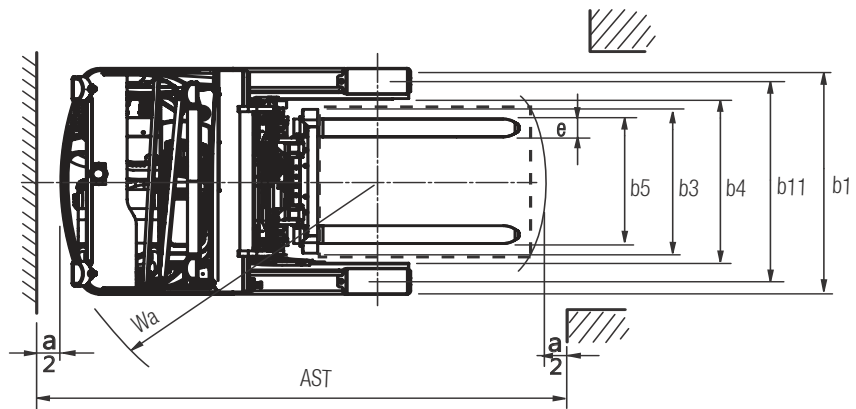
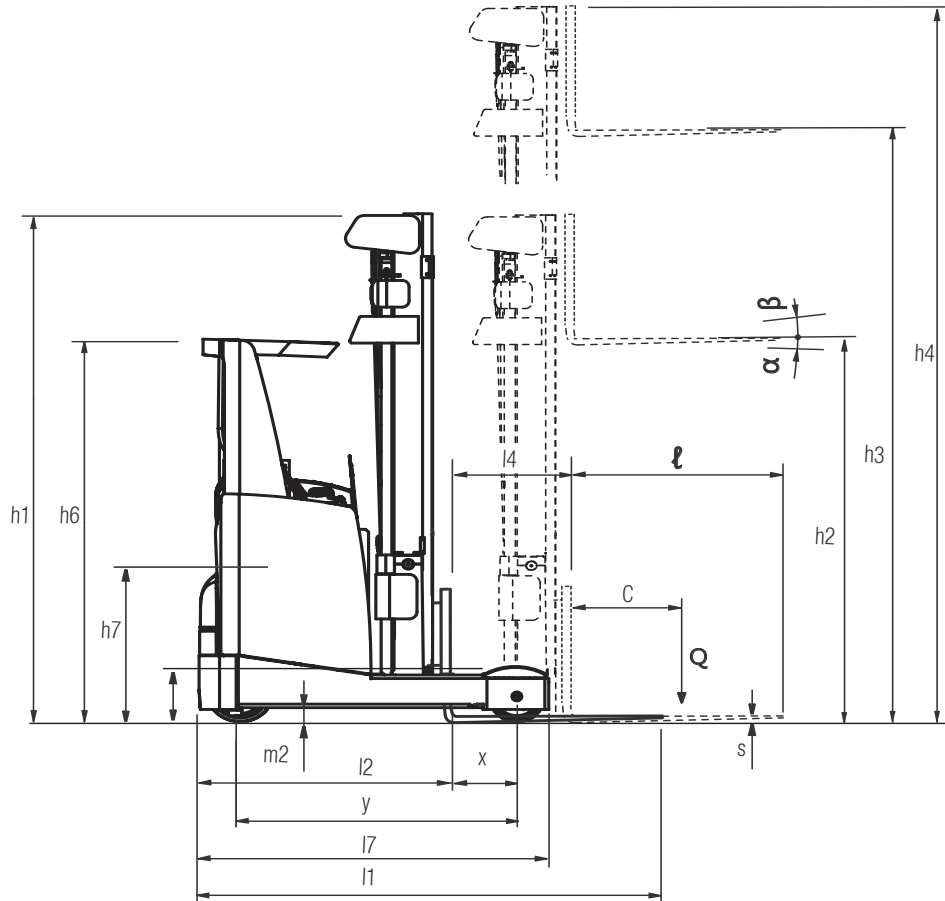

$$R = \sqrt{(l_6 - x)^2 + \left(\frac{b_{12}}{2}\right)^2}$$

$$R_h = \sqrt{x^2 + \left(\frac{b_{12}}{2}\right)^2}$$

$$A_{st} = W_a + R + a \text{ if } R_h < W_a$$

$$A_{st} = R_h + R + a \text{ if } R_h > W_a$$

For corresponding data see specification chart.

# SPECIFICATIONS



## Product Specifications acc. to VDI 2198

	1.1 Manufacturer (Abbreviation)	CLARK	CLARK	
Specifications	1.2 Manufacturer's designation	SRX14	SRX16	
	1.3 Drive unit	Electric 48V	Ele 48V	
	1.4 Operator type	Rider-seated	Rider-seated	
	1.5 Load capacity/rated load	Q (kg)	1400	1600
	1.6 Load center distance	c (mm)	600	600
	1.8 Load distance 1)	x (mm)	314	364
	1.9 Wheelbase	y (mm)	1410	1460
Weight	2.1 Service weight including battery (s. 6.5)	kg	3280	3290
	2.3 Axle loading, fork retracted, unladen front/rear	kg	1948/1319	2000/1277
	2.4 Axle loading, forks forward with load front/rear	kg	658/4009	551/4325
	2.5 Axle loading, forks retracted with load front/rear	kg	1669/2998	1747/3130
Tyres, Chassis	3.1 Tyres	Polyurethane	Polyurethane	
	3.2 Tyre size, front	Ø343 x 114	Ø343 x 114	
	3.3 Tyre size, rear	Ø285 x 100	Ø285 x 100	
	3.5 Wheels, number front/rear (x=drive wheels)	1x/2	1x/2	
	3.6 Tread, front	b10 (mm)	-	-
	3.7 Tread, rear	b11 (mm)	1132	1132
	Dimensions	4.1 Fork carriage tilt, $\alpha$ =forward/ $\beta$ =backwards	deg.	3/4
4.2 Height, upright lowered		h1 (mm)	2545	2545
4.3 Free lift		h2 (mm)	1647	1647
4.4 Lift height		h3 (mm)	5500	5500
4.5 Height upright extended		h4 (mm)	6413	6413
4.7 Height of overhead guard		h6 (mm)	2200	2200
4.8 Seat height		h7 (mm)	990	990
4.10 Height of support arms incl. load wheel cover		h10 (mm)	310	310
4.19 Overall length 1)		l1 (mm)	2451	2451
4.20 Length to face of forks 1)		l2 (mm)	1301	1301
4.21 Width		b1 (mm)	1270	1270
4.22 Fork dimensions		s • e • l (mm)	40 x 100 x 1150	40 x 100 x 1150
4.23 Fork carriage ISO 2328, A, B			Class II A	Class II A
4.24 Fork carriage width		b3 (mm)	789	789
4.25 Width across forks min/max		b5 (mm)	342/750	342/750
4.26 Width between support arms		b4 (mm)	920	920
4.28 Mast reach 1)		l4 (mm)	501	596
4.31 Ground clearance minimum, unladen	m (mm)	95	95	
4.32 Ground clearance center of wheelbase	m2 (mm)	65	65	
4.33 Stacking aisle for pallets (l6xb12)1000x1200 across 1)	A <sub>st</sub> (mm)	2731	2744	
4.34 Stacking aisle for pallets (l6xb12) 800x1200 along 1)	A <sub>st</sub> (mm)	2792	2796	
4.35 Turning radius	Wa (mm)	1620	1670	
4.37 Length over support arms	l7 (mm)	1780	1830	
Performance	5.1 Travel speed laden/unladen	km/h	14/14	14/14
	5.2 Lift speed laden/unladen	m/s	0.4/0.7	0.4/0.7
	5.3 Lowering speed laden/unladen	m/s	0.55/0.55	0.55/0.55
	5.4 Reach speed laden/unladen	m/s	0.2/0.2	0.2/0.2
	5.8 Max. gradeability laden/unladen	%	8/13	8/13
	5.9 Acceleration time laden/unladen (0 - 15 m)	s	5.1/5.3	5.1/5.3
5.10 Service brake		electric	electric	
Drive line	6.1 Drive motor output (S2 60min)	kW	7.2	7.2
	6.2 Lift motor output (S3 15%)	kW	15.1	15.1
	6.3 Battery acc. to DIN 43531/35/36		DIN 43531A	DIN 43531A
	6.4 Battery voltage, nominal capacity	V/ AH(5hr)	48 / 465	48 / 465
	6.5 Battery weight (min/max)	kg	651/866	651/866
	6.6 Energy consumption acc. to VDI cycle	kWh/h	-	-
Misc.	8.1 Type of control		Mosfet/AC	Mosfet/AC
	8.2 Operating pressure for attachments	bar	190	190
	8.3 Oil flow for attachments	l/min	21	21
	8.4 Sound level, driver's ear according to DIN 12053	dB(A)	67.0	67.0

1) Different battery sizes change these values. All values shown are for standard reach truck with integrated side shift.

# GENERAL DATA

## Truck Capacities Capacity at different load centres

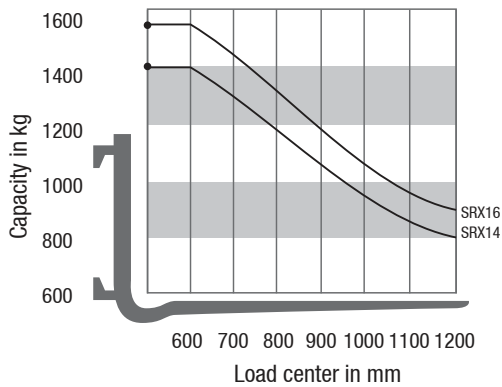

### Note:

The listed capacities are valid only for the standard upright in the vertical position and with standard forks, up to max. lifting height of 6.500 mm. The center of gravity of the load may be displaced by max. 100 mm against the longitudinal center plane of the truck. Load center is determined from top and front face of the forks. The values are based on a 1.000 mm cube load configuration with the centre of gravity at the true center of the cube. With carriage tilted forward lower capacity values are valid. Attachments, longer forks, exceptional load dimensions and higher lifting heights can reduce the capacity.

Please contact your CLARK dealer if you require further information.

## Upright Table SRX14/16

Mast type	Max. fork height (h3)	Mast lowered (h1)	Mast extended (h4)		Free lift (h2)	
			without load backrest	with load backrest	without load backrest	with load backrest
			mm	mm	mm	mm
Triplex	4.000	2.050	4.640	4.915	1.412	1.137
	4.500	2.215	5.140	5.415	1.577	1.302
	5.000	2.380	5.640	5.915	1.742	1.467
	5.500	2.545	6.140	6.415	1.907	1.632
	6.000	2.700	6.640	6.915	2.062	1.787
	6.500	2.850	7.140	7.415	2.212	1.937
	7.000	3.030	7.640	7.915	2.392	2.117
	7.500	3.210	8.140	8.415	2.572	2.297
	8.000	3.390	8.640	8.915	2.752	2.477
	8.500	3.600	9.140	9.415	2.962	2.687
	9.000	3.820	9.640	9.915	3.182	2.907
	9.500	4.000	10.140	10.415	3.362	3.087
	10.000	4.200	10.640	10.915	3.562	3.287
10.500	4.400	11.140	11.415	3.762	3.487	

## Dimensions Related to Battery Compartment Size

	1.1	Manufacturer (Abbreviation)			CLARK		CLARK		
Dimensions	1.2	Manufacturer's designation			SRX14		SRX16		
		Depth of battery compartment		mm	275	347	275	347	419
	1.8	Load center distance 1)	x	mm	1096	1168	1096	1168	1240
	4.2	Length to face of forks	l2	mm	1301	1373	1301	1373	1445
	4.33	Stacking aisle for pallets (l6xb12) 1000x1200 across	Ast	mm	2731	2786	2744	2798	2854
	4.34	Stacking aisle for pallets (l6xb12) 800x1200 along	Ast	mm	2792	2858	2796	2862	2928
	6.5	Battery voltage, nominal capacity		V/AH	48/465	48/620	48/465	48/620	48/775
	6.5	Battery weight (min/max)		kg	651/866	831/1082	651/866	875/1030	1002/1297

Performance may vary +5% and -10% due to motor and system efficiency tolerance. The performance shown represents nominal values which may be obtained under typical operating conditions of a machine. CLARK products and specifications are subject to change without notice.

# FEATURES AND EQUIPMENT

	Feature	SRX14/16
General Features	Reliable low-maintenance AC traction motor	•
	Adjustable fork width	•
	CLARK mast cushioning system	•
	Integrated sidsifter	•
	Tilting forks	•
	Working light	x
Cockpit & Instruments	Best-view overhead guard	•
	Low entrance height 380 mm	•
	Battery indicator and hour meter	•
	Electronic 180° steering	•
	Electronic 360° steering	•
	PIN-Code access control	•
	Adjustable control console	•
	Mounting bracket for additional devices	x
	Height indicator	x
	Hydraulic mini-lever control	•
	Hydraulic joystick control	x
	Emergency stop switch	•
	Interactive dash display	•
Steering direction indicator	•	
Ergonomics	Automotive layout of pedals	•
	Power-steering	•
	Adjustable backrest and seat	•
	Suspension seat vinyl or cloth	•
	Maximum legroom and best driving position	•
	Adjustable steering wheel	•
	Storage compartment	•

• = Standard Equipment; x = Option

# FEATURES AND EQUIPMENT

	Feature	SRX14/16
Battery & Charging Features	Different battery compartment sizes (SRX14 465/620 Ah / SRX16 465/620/775 Ah)	•
	Side battery removal with rollers	•
	Easy access for maintenance	•
	Various batteries and chargers	x
Performance & Productivity	Fork positioner	x
	Load wheel protection	•
	Automatic horizontal fork positioning	x
	Height preselector	x
	Automatic sidesift centering	x
	Video monitoring with camera on forks	x
	Lift and drive motor with temperature warning	•
Safety	Adjustable performance values	•
	Electronic wear-free support arm brakes	•
	Optimum all-around view	•
	Automatic travel speed adjustment	•
	Automatic parking brake	•
	Load backrest	•
	Deadman pedal	•
Maintenance & Service	Lowering limit sensor	•
	Easy access for maintenance and service	•
	Fault diagnostic via display	•
	ZAPI AC controller	•

• = Standard Equipment; x = Option

Dealer:

**CLARK Europe GmbH**

Dr.-Alfred-Herrhausen-Allee 33  
47228 Duisburg / Germany  
Tel.: +49 (0)2065 499 13-0  
Fax: +49 (0)2065 499 13-290

E-Mail: [Info-europe@clarkmheu.com](mailto:Info-europe@clarkmheu.com)  
[www.clarkmheu.com](http://www.clarkmheu.com)